

DISCOVERING
NEW DIMENSIONS



TIRE MANUFACTURING EQUIPMENT

CUTTING TECHNOLOGY

Steel Cord Cutting Lines
Textile Cord Cutting Lines

EXTRUSION TECHNOLOGY

Cold & Hot Feed Extruders
Multiple Extrusion Lines
Roller-Head Extrusion Lines

www.konstrukta.sk

EXPERIENCE & FACTS

- ▶ ESTABLISHED IN 1953
 - ▶ HEAD OFFICE: TRENČÍN, SLOVAKIA
 - ▶ 360 EMPLOYEES
 - ▶ TURNOVER: 33 MIO EUR
-
- ▶ DESIGN & MANUFACTURING OF MACHINES
FOR TYRE PRODUCTION



PRODUCTS

KONSTRUKTA SUPPLIES ENTIRE ASSORTMENT OF EQUIPMENT FOR TYRE COMPONENT PREPARATION AREA

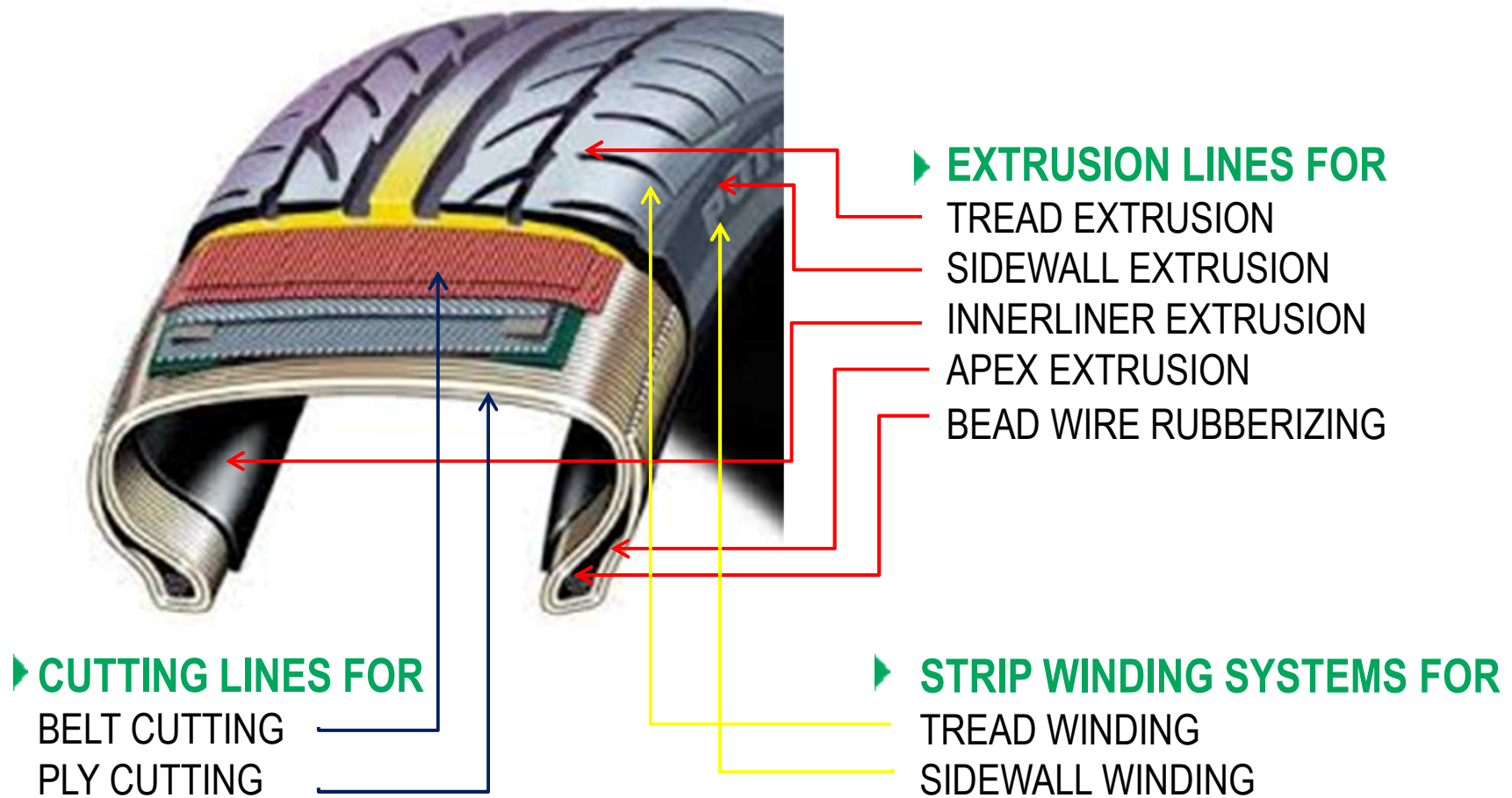

EXTRUSION LINE FOR TREAD & SIDEWALL

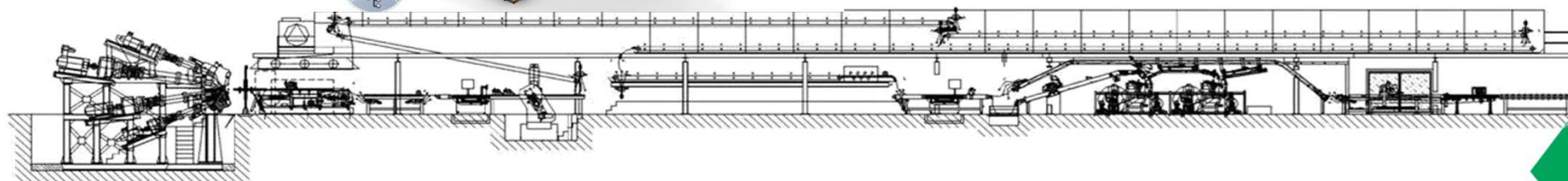
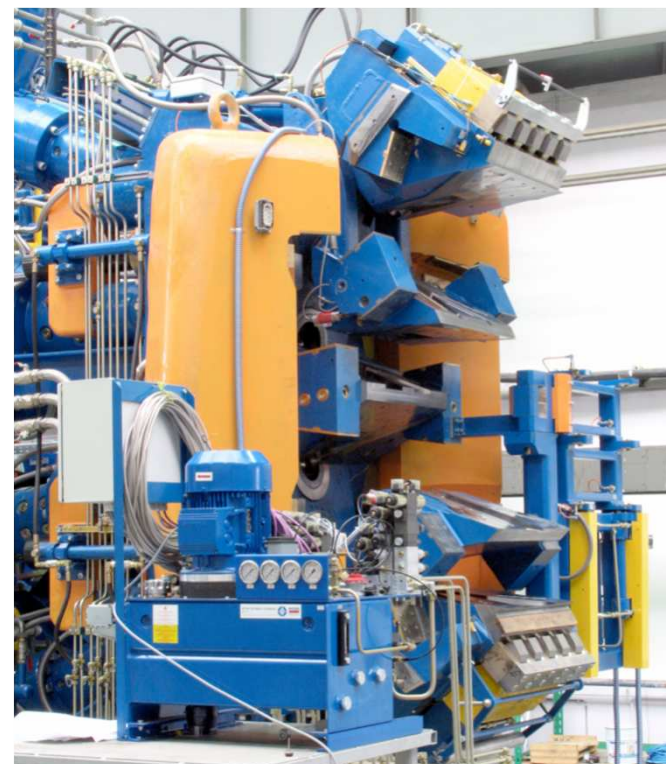

DUAL ROLLERHEAD LINE FOR INNERLINER

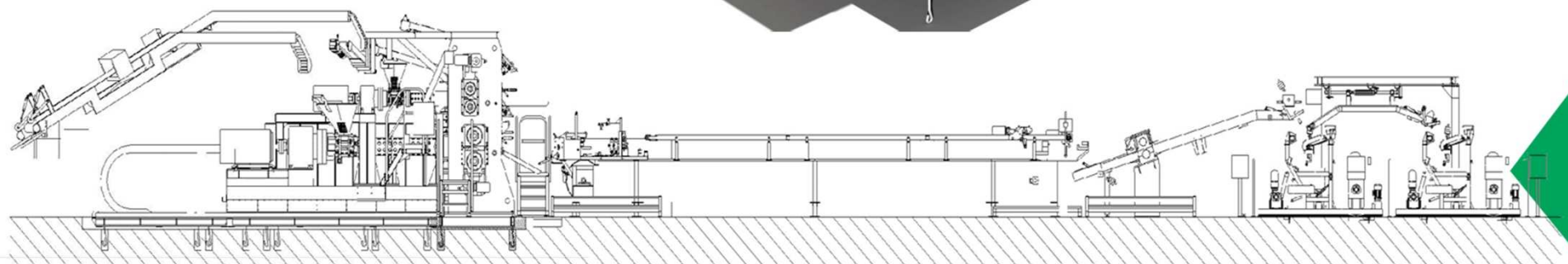
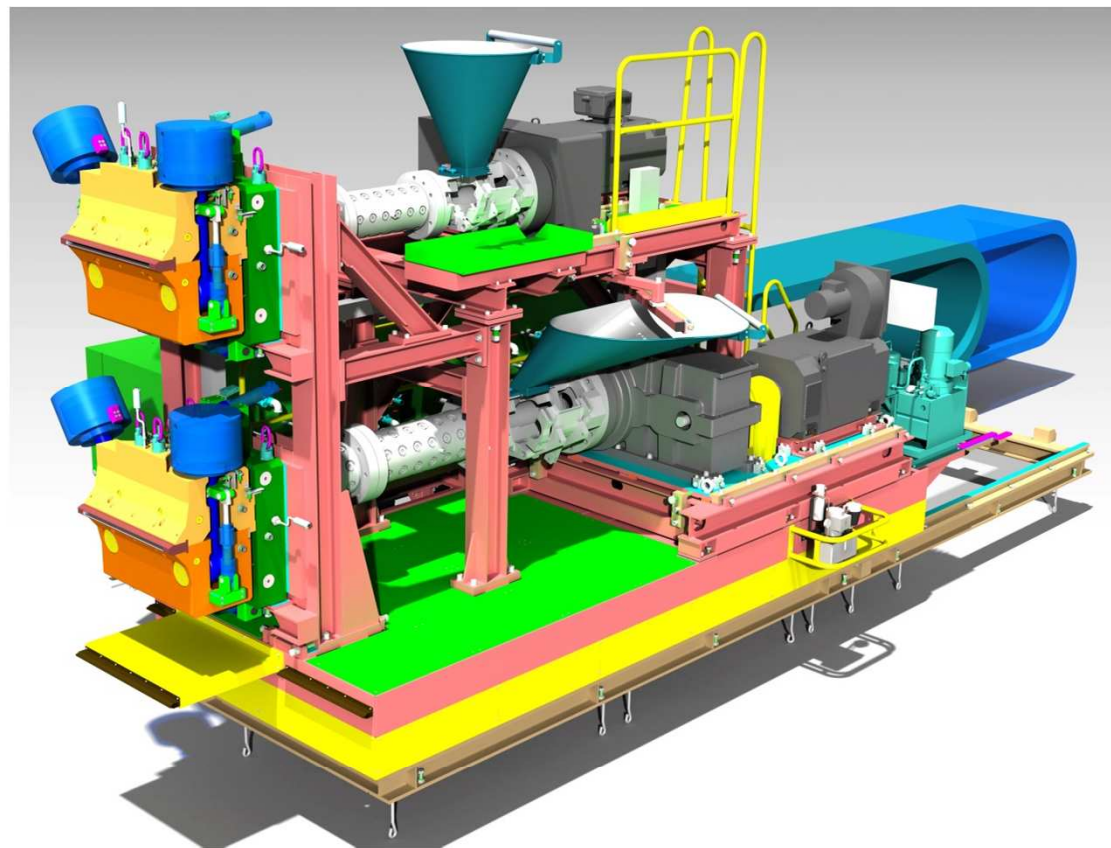
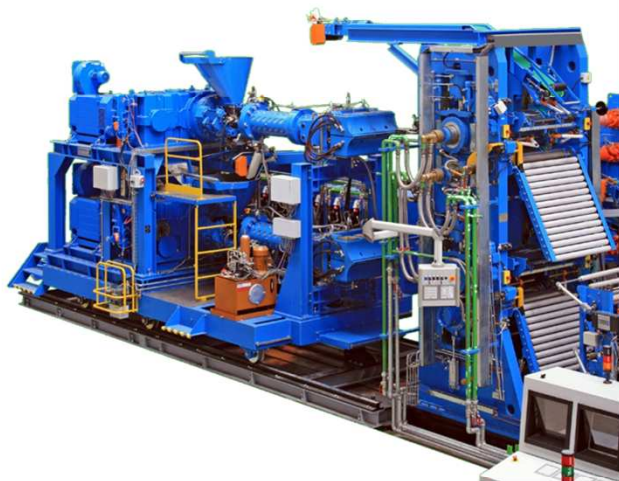

CUTTING LINE FOR STEEL BELT

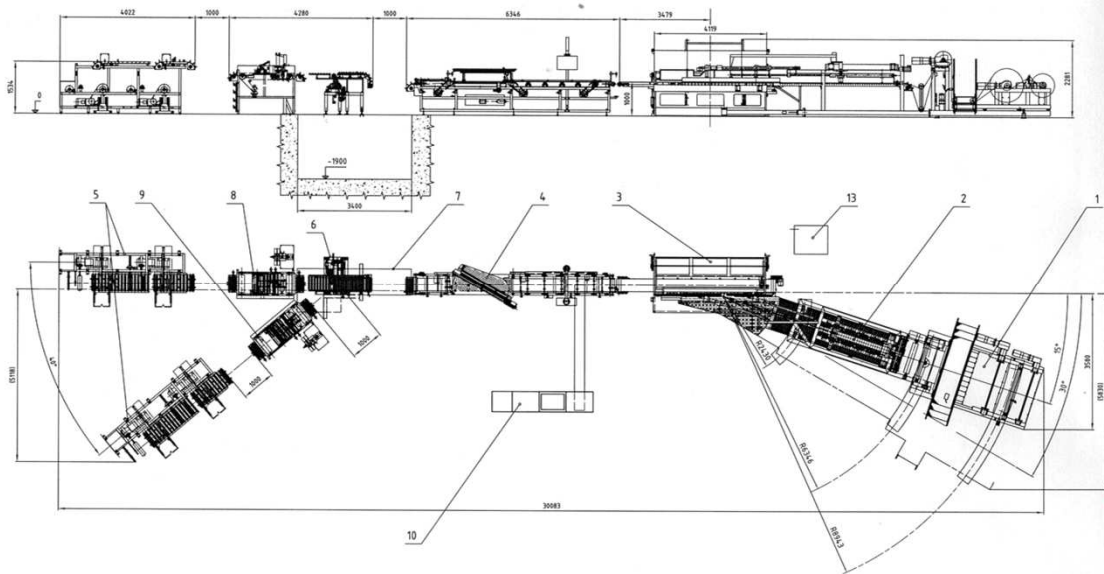

CUTTING LINE FOR STEEL BODY PLY

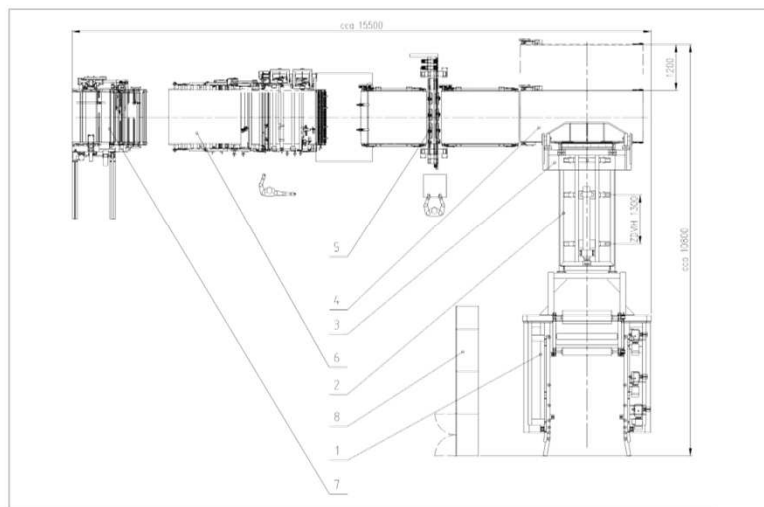

CUTTING LINE FOR TEXTILE BODY PLY

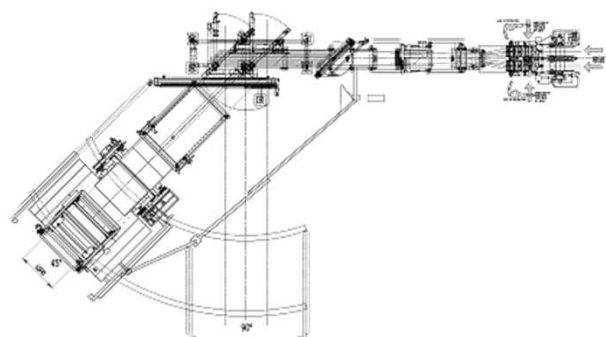
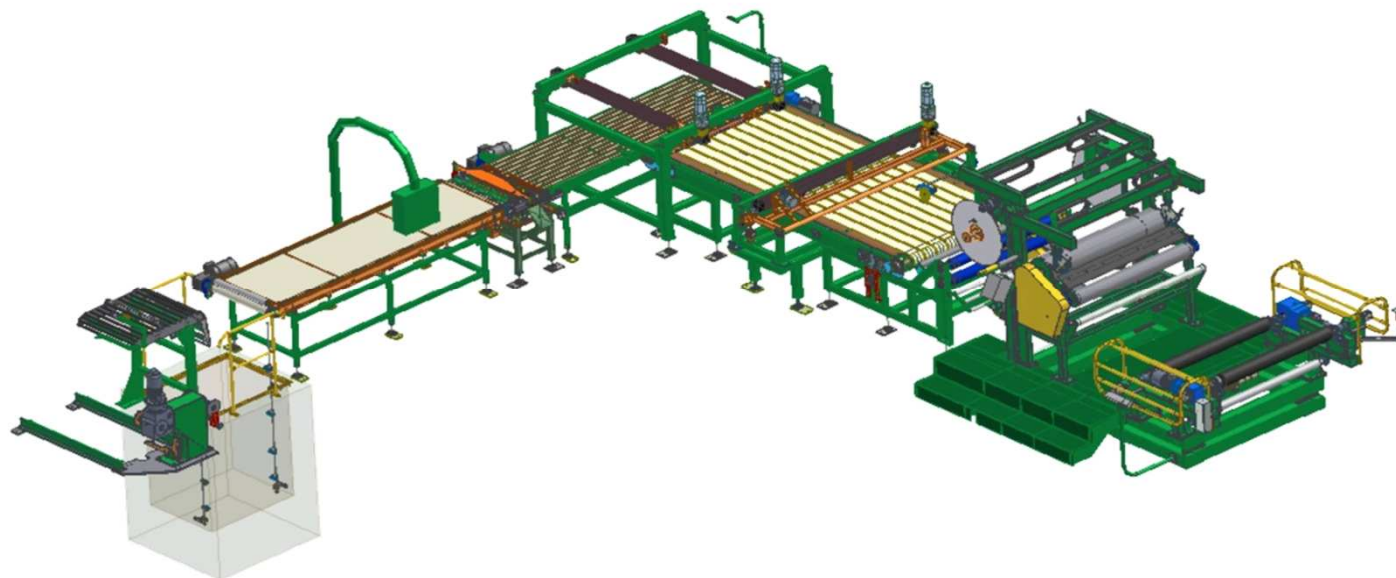
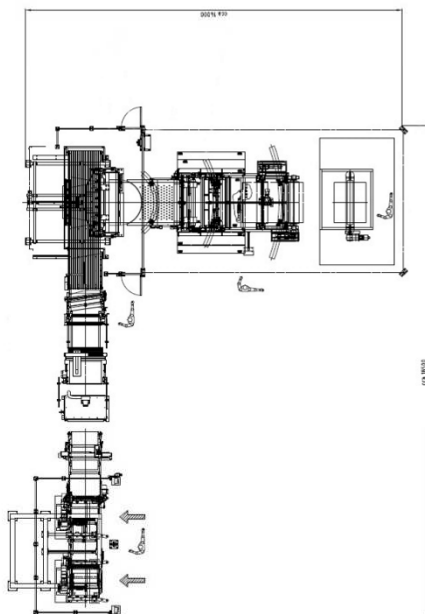

STRIP WINDING SYSTEM

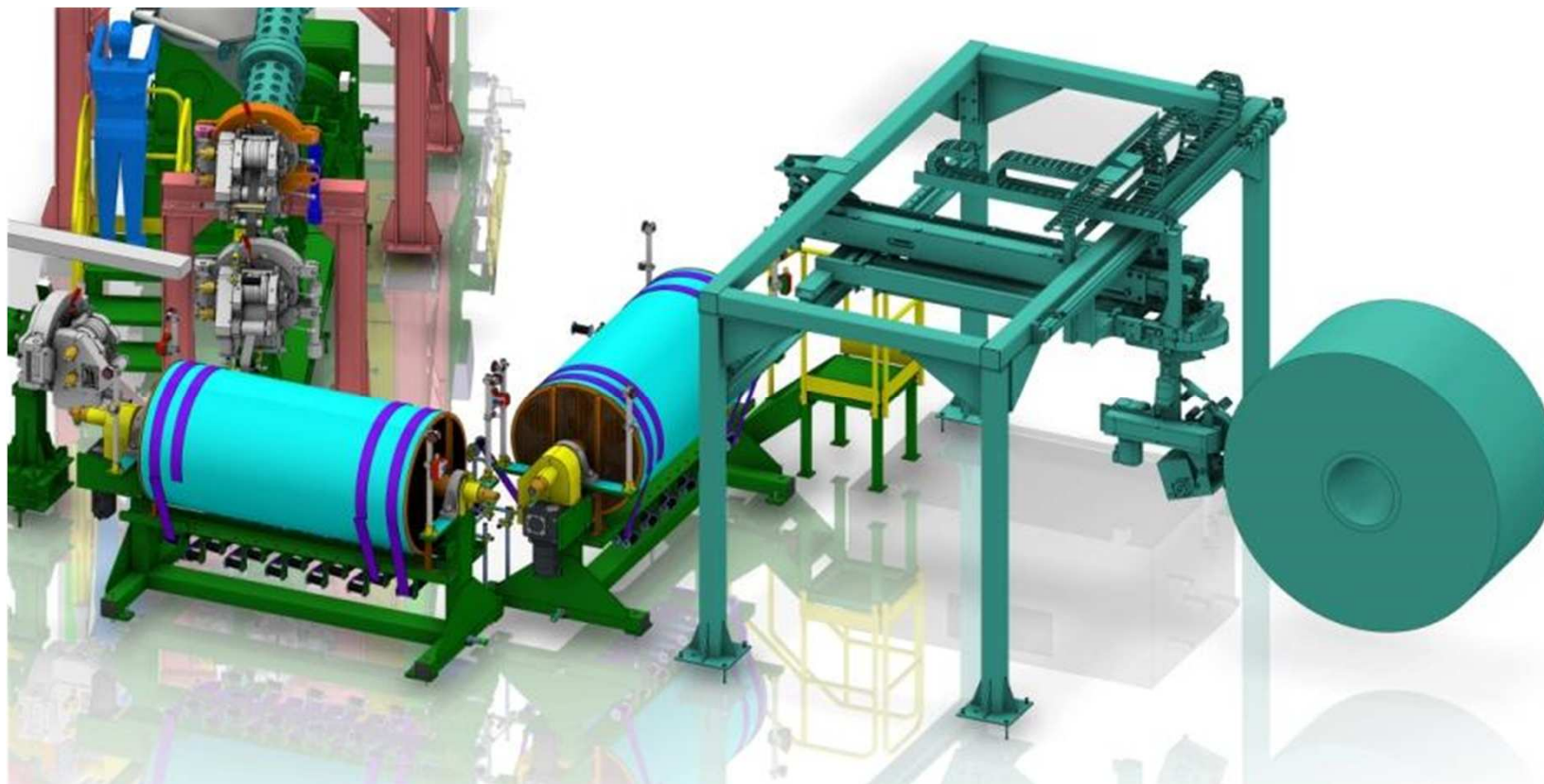

STRIP WINDING SYSTEM



OTR STRP WINDING

RESEARCH & DEVELOPMENT



- INVESTMENT FOR R&D ACTIVITIES - 1,5% OF ANNUAL TURNOVER
- OWN R&D CENTRE EQUIPPED BY ENTIRE EXTRUSION LINE
- STATE OF ART DESIGN SOFTWARE – CATIA V6

DESIGN SOFTWARE – CATIA V6

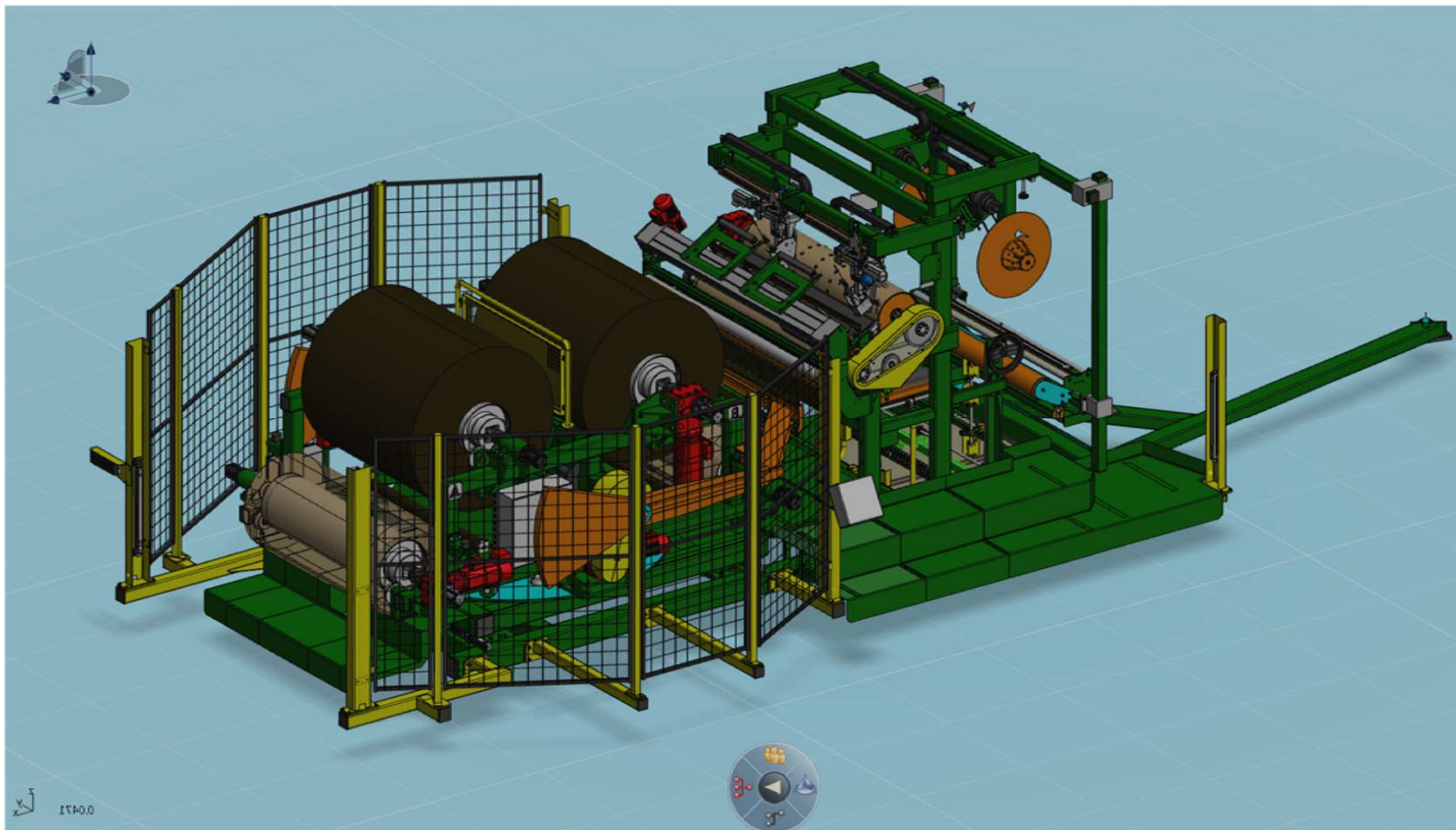

EQUIPMENT IN 64 FACTORIES OF 28 COUNTRIES

GLOBAL TIRE MAKERS



RUSSIAN FEDERATION



CHINA



AFRICA & MIDDLE EAST



SOUTH AMERICA



SOUTH EAST ASIA



KONSTRUKTA IN CHINA

SHANDONG PROVINCE

LIAONING PROVINCE

JIANGSU PROVINCE

TAIWAN

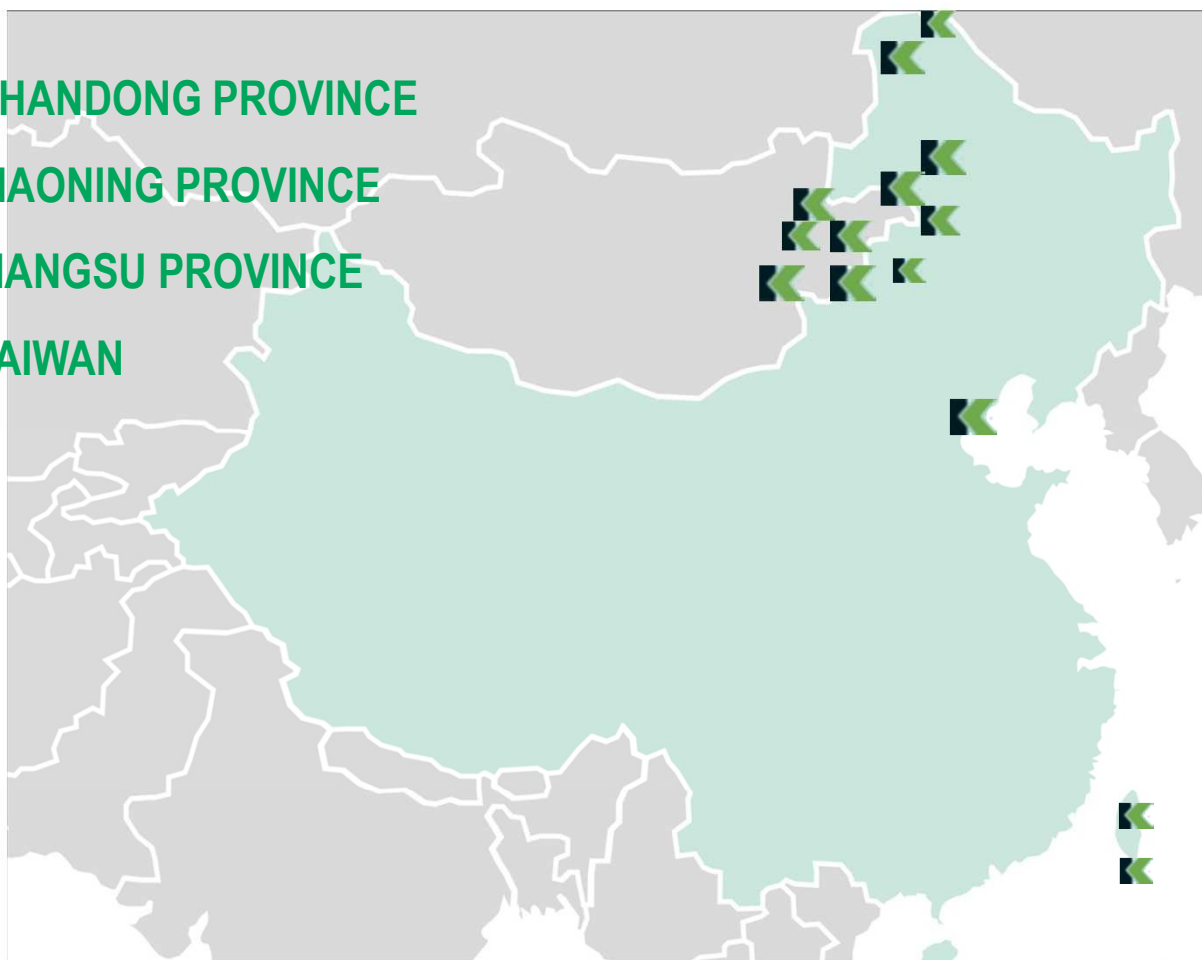

SALES STRUCTURE

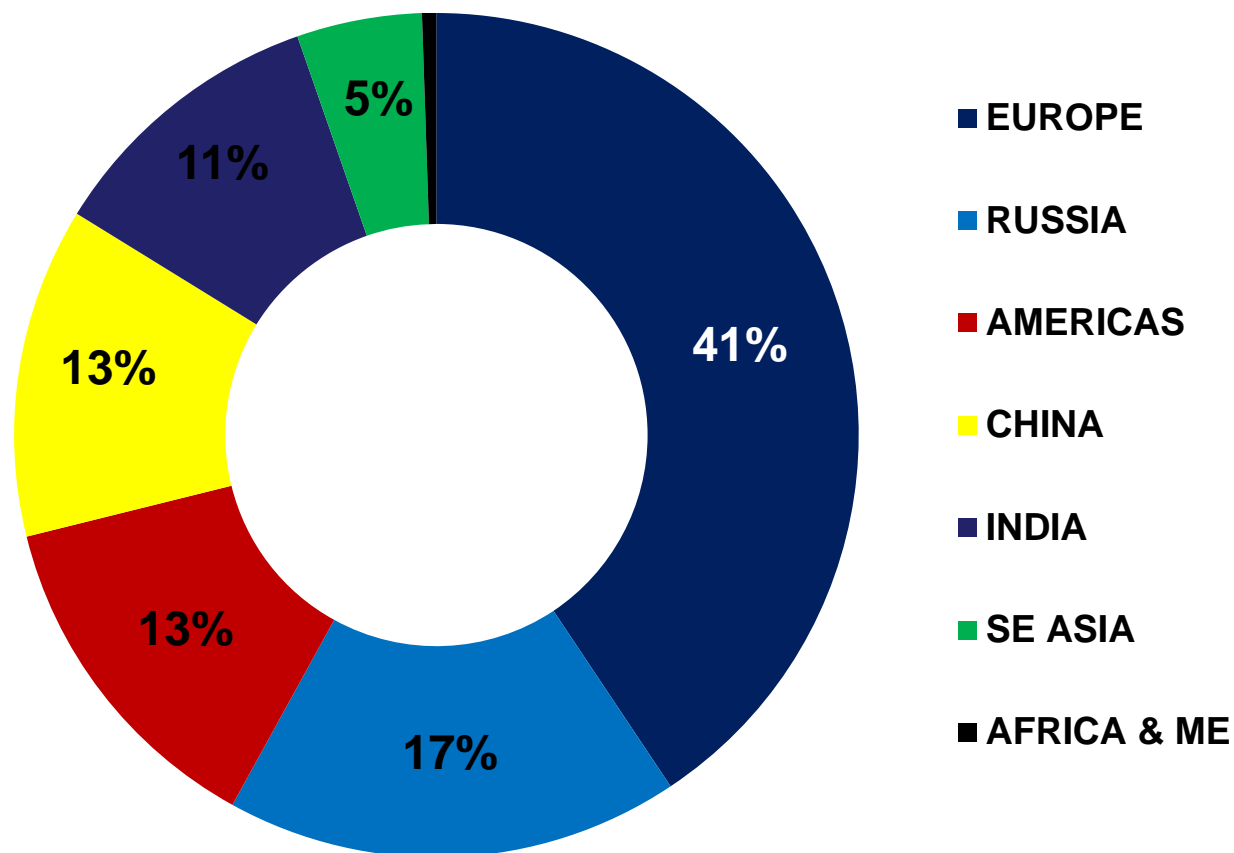

TERITORIAL STRUCTURE OF SALES IN PERIOD 2011-2014



THANK YOU FOR YOUR ATTENTION !

KONŠTRUKTA - Industry, a.s.

K výstavisku 13

912 50 Trenčín

Slovak republic

phone: +421-32-7404 551

fax: +421-32-7430 319

e-mail: sales@kotaind.sk

website: www.konstrukta.sk

